

# G2 系列 / SERIES 2-3 t

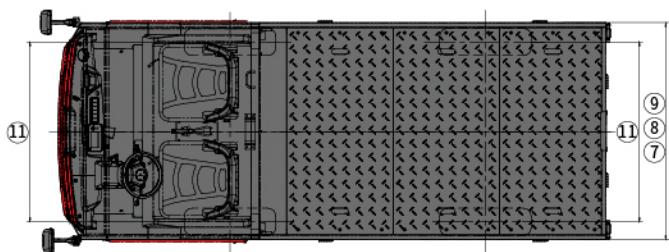

## >> 充电机技术 Charger technology

## >> 智能仪表 Smart meter

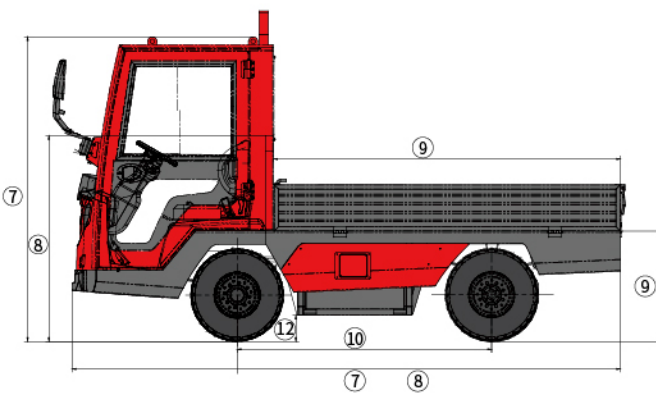
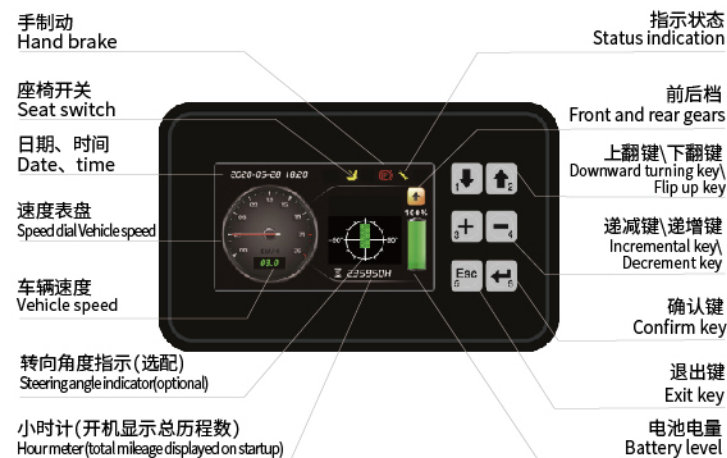

- > 高效: 大于95%充电效率, 符合节能减排要求。
- > 快速: 最快2小时可完成100%全充电。
- > 兼容: 48V/80V兼容, 满足不同电压等级需求。
- > 安全: 内置防反保护, 具备失效自隔离功能;
- > 完善的故障自检测提示, 方便客户维护。

- > High Efficiency: Charging efficiency higher than 95% meeting the requirements of energy saving and emissions reduction
- > Speediness: 100% charging realized in 2 hours at the soonest
- > Compatibility: 48 v / 80 v compatibility meeting the demand of different voltage levels
- > Safety: Built-in mis-connecting protection offering self isolating function under fault;
- > Perfect fault self checking alarm facilitating users maintenance .

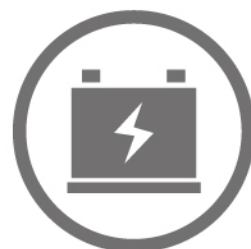

## 能量再生技术 RENEWABLE ENERGY TECHNOLOGIES

交流控制能量再生技术, 使锂电池牵引车更节能, 锂电池单作业循环时间最大延长15%。  
With AC type energy regeneration technology, the working hour of single battery shift is 15% increased.



## 技术参数 Technical Parameters

1	型号 Model	单位 Unit	BD20-J2G2Li	BD30-J2G2Li
2	驾驶方式 Driving mode		座驾式 Seated	
3	载重能力 Load capacity	t	2	3
4	自重 Weight	kg	1450(含驾驶室)/1200(不含驾驶室)	
5	空载时前后桥负载 Front-rear tires load without load	kg	650/550	
6	轮胎 Tyre	类型 Type	充气轮胎 Pneumatic tires	
		前轮 Front tire	6.50-10-10PR	
		后轮 Rear tire	6.50-10-10PR	
7	外形尺寸: 长x宽x高 (带驾驶室) (With cab) Truck dimension(length*width*height)	mm	3540x1400x1965	
8	外形尺寸: 长x宽x高 (不带驾驶室) (without cab) Truck dimension(length*width*height)	mm	3540x1400x1330	
9	平台尺寸: 长x宽x高 Platform size(length*width*height)	mm	2240x1400x680	
10	轴距 Wheelbase	mm	1650	
11	轮距 Tread	前轮距 Front tire	1160	
		后前轮 Rear tire	1160	
		后轮距 Rear tire	1160	
12	最小离地间隙 Min.Ground clearance	mm	150	
13	最小转弯半径 Min.turning radius	mm	3100	
14	行驶速度 (满载/空载) Driving speed (with/without load)	km/h	12/16	
15	爬坡能力 (满载) Gradeability(with load)	%	10	
16	行车制动 Driving brake		液压制动与电制动 Hydraulic brake and electric brake	
17	驻车制动 Traction base height		机械式 Mechanic	
18	驱动方式 Driving mode		后轮驱动 Rear Wheel Drive	
19	驱动电机额定功率 Drive motor rated power	kW	4	5
20	转向电机额定功率 Steering motor	kW	1.35	
21	锂电池 Battery	V/Ah	48/202	

标准配置 Standard configuration	选用配置 Optional configuration	锂电池选项 Lithium battery options
智能液晶显示屏 Intelligent LCD color screen	驾驶室 Cabin	环保实心轮胎 Environmentally friendly solid tire
前后桥板簧悬挂 Suspension bridge with front and rear suspension	封闭货箱 Closed container	牵引销座 Traction pin seat
充气轮胎 Pneumatic	实心轮胎 Solid tire	LED警示灯 Led warning light
液压转向 Hydraulic steering	用户自选涂装 Customized painting	
锂电池 Lithium battery	平台护板 Platform guard bar	
LED灯具 LED lamps	非标台面尺寸 Non standard table size	



安徽合力股份有限公司  
ANHUI HELI CO., LTD.  
地址 / 中国 合肥方兴大道668号  
Add / No.668, FangXing Road, Hefei, China  
邮编 (Post Code) / 230000

客服热线 (Customer Service Hotline) / 4001-600761  
服务电话 (Service Tel) / +86-551-63689667, 63689674, 63689676  
邮箱 (Web site) / heli@helichina.com

\* 本公司保留更改产品设计和规格的权利, 恕不另行通知。  
\* Our products are subject to improvements and changes without notice.

# 2-3 t

## G2系列锂电池搬运车

### G2Series Lithium Battery Platform Truck





## » 整车简介 Brief Introduction

G2系列2-3吨锂电池搬运车是合力倾力打造的新一代环保型搬运车辆，整车造型独特，按照人机工程学的原理从美学的角度去融合和升华设计形态，来满足驾驶员乘坐、操作空间、方便性及环保等一系列舒适性方面的要求。

该车型以锂电池组提供动力，采用交流控制系统进行无级调速的电动搬运车。整机高效节能，具有可靠性好，操作舒适，动力强劲等特点。

As the newly designed environmentally friendly tractor machines, HELI G2 Series Lithium Battery Platform Truck has the unique profiling, ergonomically and aesthetic philosophy combination for operator comfort and ease of use, maintenance convenience.

This machine is powered by Lithium battery, with AC control system to supply the stepless accelerating, high efficiency, reliable quality, comfortable operation, and strong power.

## 锂电池优势 Operating Cost Comparison

- 合力锂电池搬运车的优越性，更突出的体现在生命周期内使用成本上。与铅酸蓄电池叉车相比，锂电池叉车适合多班次场合，隐性成本低，整体运营成本更经济。
- The superiority of HELI lithium battery forklift truck is embodied in the use-cost within product lifecycle. Compared with lead-acid battery forklift truck, lithium battery forklift truck is more convenient for multiple working shifts. It has lower implicit cost and more economical total running cost.

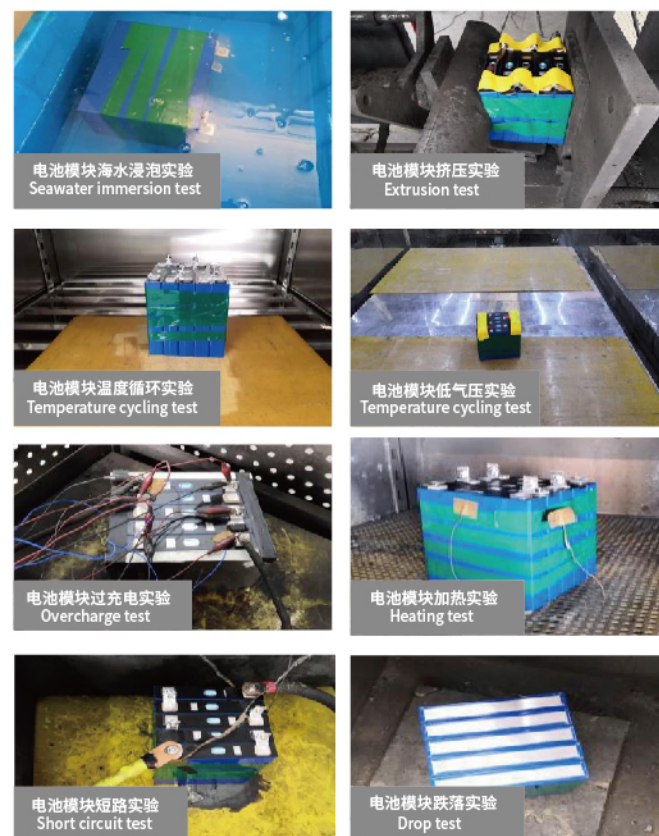
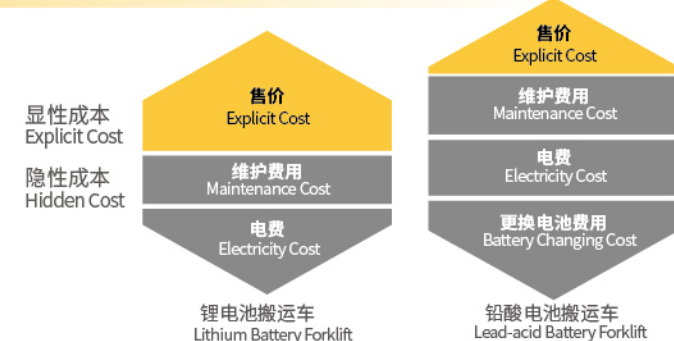

- 合力锂电池搬运车选用经济成熟的商用车大批量使用的方形磷酸铁锂电芯及模组；
- 模组采用铝合金板金框架，牢固、质轻、散热效果好；
- 充电快：可随用随充，2小时即可充满；
- 高效安全：充放电效率高达98%，热失控温度600°C以上；
- 低温适应性：标配电加热功能，保证低温环境正常工作；
- 长寿命：正常充放电循环3000次以上或者5年，容量保持率大于75%；
- 免维护：电池无需人工维护，无需加蒸馏水电解液；
- 绿色清洁：无污染，零排放。

- The truck selects mature and economical square iron phosphate lithium battery core and module used by large numbers of commercial vehicles;
- The module adopts aluminum alloy plate frame, which is firm, light in weight and has good heat dissipation effect;
- Fast charging: fast charging makes truck gapless operation possible, and it can be filled in 2 hours;
- High efficiency and safety: The charging and discharging efficiency is up to 98%, and temperature of thermal runaway is over 600 °C;
- Low temperature adaptability: Standard configuration of heating function ensures normal operation of low temperature environment;
- Long service life: the normal charging and discharging cycles is more than 3000 times or 5 years, and capacity retention rate is more than 75%;
- Maintenance free: the battery does not need manual maintenance and does not need to add distilled water electrolyte;
- Green and clean: no pollution and zero emission.

## 驱动系统 Drive system

- 电动车专用驱动桥，噪音小、无污染、运行平稳、密封性能好。同时具有较大的离地间隙，保证本车具有良好的通过性
- 传动比大、牵引力大；爬坡能力强，性能卓越，满足路面复杂的场合
- Special drive axle for electric machines with low noise, non-pollution, stable running, perfect sealing, and also with enough ground clearance for good trafficability.
- Large gear ratio, powerful traction, strong gradeability, perfect performance, suitable for complex operating condition.

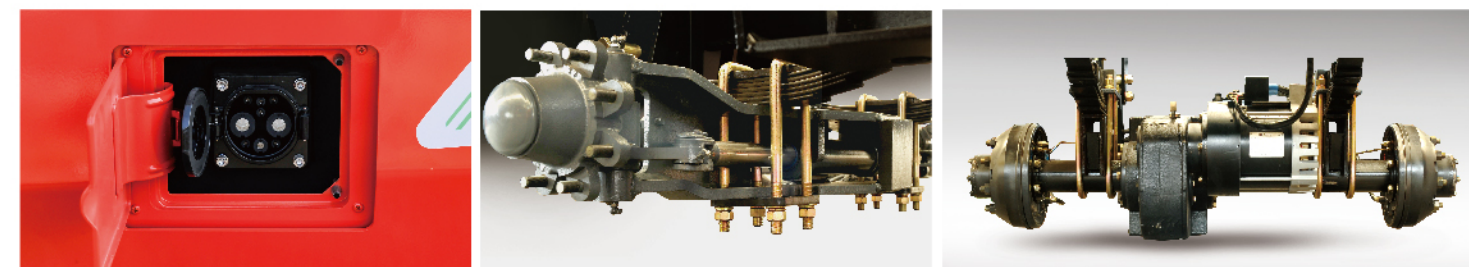

## 转向系统 Steering system

- 本车采用全液压横置油缸转向桥实现前轮转向，该转向系统具有效率高，操作轻便，使用寿命长，转向灵活轻便等特点
- 前后悬挂采用弹性连接，整机舒适性好
- With fully-hydraulic Transverse cylinder power steering, easily steering, and long working life.
- Front and rear suspension are with elastic connection for more comfort.

## 更加优越的智能化设计 Superior intellectualized design

- 更多智能化设计的装备与功能使整车智能，这不仅保护驾驶者和整车安全，还提高工作效率，降低了能耗。
- Superior intellectualized designs not only ensure operator and truck safety but also improve working efficiency, reduce energy consumption.

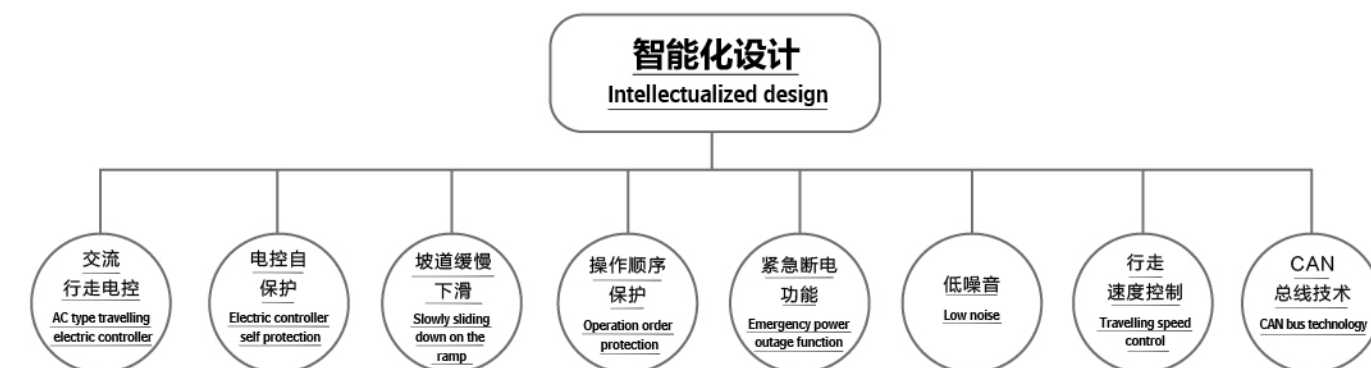

## 操纵系统 Operating system

- 合理的制动踏板、加速踏板的角度及位置，轻巧的踏板力，充分满足人机工程要求
- 采用可调式方向盘，方向盘的位置可前后调节，以适应不同体形驾驶员操纵的要求
- 具有良好的冷态制动效能，产生足够的制动力，使行车制动和驻车制动性能符合强制性标准的要求
- Comfortable brake/accelerating pedal position with light stepping strength, fully meeting ergonomically demands.
- With front-rear adjustable steering wheel to satisfy different height drivers.
- With excellent cold-brake efficiency, enough brake force, fully meet the parking and driving brake standard.



整车选配：驾驶舱 Optional: Cab